

Chapter 1

INDUSTRIAL DEVELOPMENT STRATEGY IN CLMV

Ikuo Kuroiwa

ABSTRACT

This chapter seeks to provide a framework of industrial development strategy in Cambodia, Lao PDR, Myanmar, and Vietnam (CLMV). In considering appropriate industrial development strategy, two constraints on industrial policy—shrinking policy space and the constraints on state capability—seem to be critical. In particular, the World Trade Organization (WTO) and free trade agreements (FTAs) have narrowed policy space and made many of infant industry protection policies illegal. On the other hand, it is still uncertain if CLMV are endowed with sufficiently strong institutional capabilities to implement industry-specific policies. This chapter discusses an alternative industrial development strategy whereby participation in production networks and formation of competitive clusters play a critical role.

INTRODUCTION

In East Asia, a rapid decline in trade and transport costs due to liberalization in trade and investment as well as infrastructure improvement and technological progress has facilitated multinational enterprises (MNEs) to organize production networks internationally. Many MNEs have shifted labor-intensive production activities to less developed countries. Local firms are able to participate in these networks and obtain not only market access but also technological transfer from MNEs. On the other hand, the relocation of production activities by MNEs would invite other production activities via vertical (backward and forward) linkages.

To encourage the above processes of production networking and industrial clustering, heterogeneity and geographical proximity are crucial. Such characteristics are observable in less developed countries in Southeast Asia especially CLMV. The significant wage gap between CLMV and the more developed East Asian countries induce MNEs to shift labor-intensive activities to the former. Moreover, CLMV are

located in the center of East Asia, sharing borders with China and Thailand. Such geographical proximity is propitious in facilitating the movement of goods, services, investment, and natural persons, especially now that border barriers are being removed with the support of the ASEAN Free Trade Agreement (AFTA) and other regional frameworks. Furthermore, infrastructure development, such as the East-West, North-South, and Southern Economic Corridors, are significantly reducing transport cost and time in this region. Eventually, it will lead to the reconfiguration of corporate activities, so that production networks can spread into less developed regions.

This chapter seeks to provide a framework for industrial development strategy in CLMV focusing on the following: (1) review of industrial policies in Southeast Asia ; (2) two constraints on industrial policy—shrinking policy space and the constraints on state capability; (3) introduction of theories of production fragmentation and concentrated dispersion; and (4) re-examination of industrial policies in CLMV particularly policy measures on participation in production networks and the formation of competitive industrial clusters.

1. INDUSTRIAL POLICIES IN SOUTHEAT ASIA

Similarities exist in industrial policies in Southeast Asian countries. Table 1 shows that Singapore was the only country which switched to an export-oriented industrial (EOI) policy after its independence from Malaysia in 1965. On the other hand, other larger economies adopted an import substitution industrial (ISI) policy in the 1950s or 1960s before proceeding to secondary ISI policies. Although Malaysia switched to an EOI policy in the 1970s, its ISI policy has continued simultaneously. In the middle of the 1980s, after Southeast Asian countries faced adverse economic conditions such as declining and fluctuating prices of primary commodities and limited success of ISI policies, all of these countries started to liberalize trade and investment.

As shown below, EOI policies or liberalization in trade and investment was critical in assisting the spread of production networks in Southeast Asia, and similar development is expected to happen in the late-coming countries, because of their economic transition since the mid-1980s.

Table 1: Evolution of Industrial Policies in Southeast Asia, 1950s-1990s

Economy	1950s	1960s	1970s	1980s	1990s
Singapore	1950s IS (while still part of Malaya)	1960s-1980s EO			1990s Strategic independence (high technology and services) Regionalization
Malaysia	1950-70 Moderate IS Added EO		1971-85 Continued IS EO		1986- Liberalization
Thailand		1961-71 IS	1971-86 IS (capital goods, beginning in 1981)		1986- EO Technology-incentive Industries Some EO
Indonesia		1967-73 Stabilization Beginning IS	1974-85 Strong IS		1986- Liberalization EO
Philippines	1950- IS	Continued IS		1980s Liberalization (political instability)	1990s Continued liberalization (strengthened political stability)

Note: IS-import substitution, and EO-export orientation

Source: Masuyama, Vandenbrink and Chia (1997); Table 1.1

Since the mid-1980s, CLMV have been undergoing economic transition in various ways: from central planning to market economies, from inward-looking to outward-looking economic development strategies, and from close economic relations with the Soviet bloc to closer economic relations with market economies (Chia 2006). Moreover, CLMV adopted trade and investment liberalization policies practiced by the more advanced Southeast Asian countries, (i.e. removal or relaxation of foreign ownership restrictions and performance requirements and various investment incentives such as tax exemptions, duty drawbacks, and the establishment of export processing zones. Vietnam, for example, undertook substantial trade reform during its Doi Moi process in the late 1980s by addressing the anti-export bias in its earlier protective regime and introducing privatization. (Chia 2004; Narjoko and Amri 2007).

2. SHRINKING POLICY SPACE

Since the late 1990s, economic reform in CLMV has been accelerated by their accession to the WTO and the establishment of FTAs. Myanmar joined the WTO in 1995, Cambodia in 2004, and Vietnam in 2007. Lao PDR applied for WTO membership in 1997 and negotiations are still ongoing. On the other hand, Vietnam joined the Association of Southeast Asian Nations (ASEAN) and signed the ASEAN Free Trade Area (AFTA) agreement in 1995; Myanmar and Lao PDR in 1997; and Cambodia in 1999. Unlike economic reforms undertaken by countries at their own initiative, the forces establishing liberalization under the WTO and FTAs are formal and rule-based. Therefore, rules are more stringently enforced and policy space, which defines a range of policy choices available to member countries, is constrained accordingly.

The impacts of the WTO on the industrial policy instruments, such as tariff protection, Subsidies and Countervailing Measures (SCM), Trade-Related Investment Measures (TRIMs), Trade-Related Aspects of Intellectual Property Rights (TRIPS), General Agreement on Trade in Services (GATS) and others are summarized in Table 2. On the other hand, FTAs seeks to remove trade barriers within the specified region, but as ASEAN integration moves from AFTA to the ASEAN Economic Community (AEC), the policy space available to each ASEAN country will be constrained further, because the AEC aims to liberalize not only trade but also service trade and investment.

In such a context, the traditional debate about efficacy of infantry industry protection has become less relevant, as many of these policies are illegal under the rules of the WTO and FTAs (Bora, Lloyd, and Pangestu 2000; Strugeon and Lester 2004). It is more relevant to explore the industrial policies that are effective in the age of market liberalization and globalization, when participation in the WTO and FTAs are becoming the norms.

Table 2: Impacts of the WTO Rules on Industrial Policy Instruments

WTO rules	Impacts on industrial policy instruments
1. Tariff protection	Average tariff protection has declined except for certain sensitive industries
2. The Agreement on Subsidies and Countervailing Measures (SCM)	The Agreement on Subsidies and Countervailing Measures (SCM) prohibits export subsidies by countries with income per capita above US\$1,000. Subsidies that are conditional on exports are prohibited, as are subsidies that encourage the use of domestic rather than imported inputs.
3. The Agreement on Trade-Related Investment Measures (TRIMs)	Under the TRIMs Agreement, a number of investment performance-related measures that have an effect on trade are prohibited. Such measures include local content requirements, trade balancing requirements, technology transfer, local employment and R&D, and so on.
4. The Agreements on Trade-Related Aspects of Intellectual Property Rights (TRIPS)	The required strengthening of protection of intellectual property rights under the TRIPS agreement increases a need for local companies to innovate and compete dynamically; reverse engineering and imitation have become less feasible. Trade sanctions can now be applied to countries deemed to be deficient protecting intellectual property rights.
5. General Agreement on Trade in Service (GATS)	The GATS allows sectoral commitments to be made for the four modes of supplying services: cross-border, consumption abroad, commercial presence, and movement of natural persons. Through the inclusion of commercial presence as a mode of supply, rules on foreign investment in services have now become part of the multilateral trading system.
6. Infant Industry Protection	GATT Article XVIII, Section A and C, allows members that are in early stages of development to use trade barriers to protect domestic industry. As tariff bindings expand, developing countries may have to rely increasingly on Article XVIII, along with safeguards and domestic subsidy programs, to protect domestic industry.
7. Special and Differential (S&D) Treatment by WTO	The WTO has numerous special and differential treatment provisions in favor of developing countries. The approach to S&D treatment in the WTO, however, has typically been limited to transitional arrangements, complemented by the <i>de minimis</i> provisions.

Source: Bora, Lloyd, and Pangestu (2000), Pangestu (2002) and Lall (2003)

3. CONSTRAINTS ON STATE CAPABILITIES

One of the important lessons learned from the public policy dispute in the 1990s was the importance of institutional capabilities in considering appropriate industrial policies. For example, if the institutional capability of the state is too weak, then any selective government intervention, which gives government officials strong discretion over which industries to be protected by the state will not work or may simply induce opportunistic activities, such as rent-seeking, and lead to allocative inefficiency. The costs of government intervention (i.e., loss in economic efficiency due to government failures) may exceed its benefits (i.e., gain in economic efficiency due to correction of market failures). Thus, to prevent government intervention from becoming too costly, it is urged to match the state's role with its capability (World Bank 1997).¹

State capability relevant to industrial policy is not easy to assess where ordinary governance indicators, such as corruption and the rule of law, may not be appropriate. In fact, the Asian newly industrialized economies (NIEs)—such as Korea and Taiwan—were not free from corruption in their early phase of development but still enjoyed rapid economic growth. On the other hand, McKendrick et al. (2000) argues that two sets of related institutions are important for successful implementation of industry policy—cohesive and autonomous bureaucracies and mechanisms for public and private sector consultation. It is also important to establish a well-organized monitoring system for promoted industries and avoid political intervention.

Although more efforts must be made to assess institutional capabilities of less developed Southeast Asian economies, it is still uncertain if they are endowed with sufficiently strong institutional capabilities. In fact, some economists including Ohno argued that Vietnam lacks state capability for industrial policy where recommendations were made regarding institutional reforms in the government sector. According to Ohno

¹ This approach was officially demonstrated by the World Bank's two-part strategy (World Bank 1997). The two-part strategy has two elements. Matching the state's role to its capability is the first element. In particular, where state capability is weak, how and where the state intervenes should be carefully assessed; many states try to do too much with little capability and often do more harm than good. The second element of the strategy is to raise state capability by reinvigorating public institutions.

(2003), Vietnam's policy process has no effective mechanisms for collecting detailed and up-to-date information on domestic industries and global markets. Thus, he urged the government to institutionalize regular dialogue between policymakers and domestic and foreign firms for policy formulation. He also pointed out the lack of coordination among sectoral ministries and urged the concentration of authority by setting up a special team under the Prime Minister.

In considering the efficacy of industrial policy, the above two constraints—shrinking policy space and the constraints on state capability—are becoming increasingly important. Below the author discusses an industrial development strategy whereby participation in international production networks and the formation of competitive industrial clusters plays a critical role. In this strategy, liberalization in trade and investment, which has been accelerated by the WTO and FTAs, is fully incorporated and even encouraged to seize opportunities provided by the momentum of market liberalization.

4. FRAGMENTATION

The production of a final product usually consists of a number of processes that are vertically integrated. Production fragmentation means to divide such vertically integrated production processes into separate production blocks (PBs) and to locate them at various sites that are most suitable for each activity (Figure 1). Jones and Kierzkowski (1990) present an initial framework for analyzing production fragmentation. They formulated an analytical framework in which an increase in the number of production blocks lowers total production costs; lower production costs are realized especially when a labor-intensive production block is relocated to a lower-wage country. On the other hand, an increase in the number of production blocks incurs additional fixed costs (i.e., setup costs of a new factory in the lower-wage country) and higher service link costs² (i.e., costs for transporting intermediate inputs and coordinating production activities across

² Production blocks are connected via service links such as bundle of activities consisting of transportation, insurance, telecommunication, quality control, and management coordination to ensure that the production blocks interact in the proper manner (Arndt and Kierzkowski 2001).

borders) are required to join up distant production blocks. Therefore, insofar as the setup costs and service link costs are reduced substantially, previously vertically integrated production processes are fragmented into separate production blocks, and activities of firms are dispersed geographically.

Figure 1: Before and After Fragmentation

Before fragmentation



After fragmentation

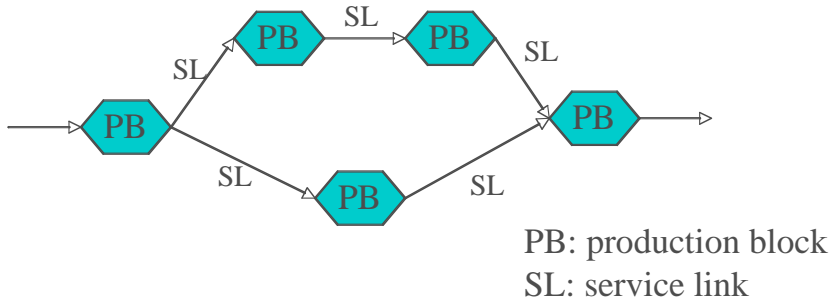

Source: Kimura (2008).

It is, however, notable that production fragmentation does not occur in all industries. According to Lall et al. (2004), the intensity of fragmentation differs according to industry, depending on four factors: (1) technical 'divisibility' of production processes; (2) differing factor intensity of production processes (only labor intensive processes can be efficiently relocated to lower-wage sites); (3) technological complexity of each process (only simple and stable process can be efficiently relocated); and (4) the value-to-weight ratio of the product (only light weight and high value-added products can be shipped long distances to exploit cost differences).

In a separate article, Lall (2003) argued that in high-technology industries, fragmentation is strong in electronics; in medium-technology industries, fragmentation is strong in automotives but the weight of the product and its high basic capability

requirements mean that it only extends to a few proximate, relatively industrialized locations; and in low-technology industries, production fragmentation is strong in clothing, footwear, sports goods, and toys.

Empirical studies show that production fragmentation in East Asia has been driven by machinery industry. In particular, the electronics industry established a dense production network and became a leading force of economic integration in East Asia. This occurred because many parts and components in electronics are small and light. At the same time, they have relatively high added value, so that they can be shipped long distances (Kuroiwa 2008; Ando 2009).

On the other hand, many parts and components in the automotive industry are bulky and heavy. Therefore, automotive assemblers have strong incentives to save on transport and inventory costs by procuring their parts and components locally. In addition, just-in-time production may increase the importance of geographical proximity. The empirical studies show that its dependency on imported inputs were relatively low, with production networks extending only within the ASEAN region after the introduction of regional frameworks such as the Brand to Brand Complementation (BBC), the ASEAN Industrial Cooperation (AICO) Scheme, and AFTA (Kuroiwa 2008, 2009).

Sewing and assembly of garments accounts for 80 percent of all labor costs in clothing manufacture (Dicken 2007). Thus, such an extremely labor-intensive process is separated from other processes and shifted to low-wage countries. Empirical studies, however, show that in recent years the wearing apparel production network did not expand in leading Southeast Asian countries. This occurred because high income Southeast Asian countries were no longer competitive in the wearing apparel industry, and thus there was no strong incentive to expand the production network. Instead the industry's network expanded into less developed countries, including CLMV (Kuroiwa 2009).

Production networks in the Southeast Asian countries expanded in the automotive and electronics industries. In particular, the electronics industry, which had established a dense production network, became a leading force of regional integration. On the other hand, the wearing apparel industry did not expand network in high income Southeast Asian countries.

5. AGGLOMERATION AND CONCENTRATED DISPERSION ³

There is a significant difference in labor costs between neighboring countries in Southeast Asia. For example, labor costs in Thailand are 4.8-8.0 times higher than in Lao PDR (Suzuki 2009), and the worker's minimum wage in Singapore was 5.4 times as high as in Batam in 2006 (JETRO 2008). Thus, the firm always has a strong incentive to extend a production network into less developed countries. In particular, if the industry has weak agglomeration economies, production blocks are dispersed geographically. For instance, labor-intensive activities such as garment sewing are constantly relocated to low-wage countries. In this case, the industrial location closely reflects the regional structure of comparative advantage, and it changes as the endowment structure evolves over time.

In contrast, if the industry has significant agglomeration economies, the industrial location may appear to be lumpy. Firms are likely to cluster in a limited number of attractive regions, leaving other regions sparse. In this case, the centripetal force of the agglomeration economies dominates the centrifugal force provided by low wages and rents in sparse regions. Classical examples of such agglomeration are: (1) the automobile industry clustered in Detroit and Aichi, Japan; (2) financial services in New York, London, Frankfurt and Tokyo; (3) IT industries in Silicon Valley, and so on. More recently, a growing number of industrial agglomerations have also been arising in the emerging countries of East Asia—for instance, the pickup truck cluster in Thailand, the IT cluster in Malaysia, the mobile phone cluster in Beijing-Tianjin, as well as the huge multi-industry agglomerations in the Zhu Jiang (Pearl River) and Chang Jiang deltas.

Several origins of agglomeration economies have been found in the field of spatial economics. Among them, (1) home market effects (HME); (2) vertical (backward and forward) linkages of industries; (3) formation of a specific input market; (4) hub formation; and (5) spillover of technical/market information are considered to be important sources of agglomeration economies (Nishikimi and Kuroiwa, 2009). Agglomeration economies usually arise in industries characterized by increasing returns

³ This section on agglomerations and concentrated dispersion is based on Nishikimi and Kuroiwa (2009).

to scale (IRS) at the firm level and/or in those carrying the local externality among neighboring firms. The agglomeration tendency of IRS industries, however, does not imply that those industries are never influenced by dispersion forces. In fact, they may leave the agglomerate areas once they find that wages and rents in the less agglomerate area are sufficiently low to compensate less favorable business environment in the latter. Moreover, it is often observed that saturated agglomerates sprawl over neighboring regions or alternatively if some remote regions are connected with the agglomerated core via an efficient logistic network, the agglomeration may leap out along the network.⁴ This phenomenon is often called *concentrated dispersion* or *linked agglomeration* (Figure 2).

Figure 2: Dispersion, Agglomeration and Concentrated Dispersion

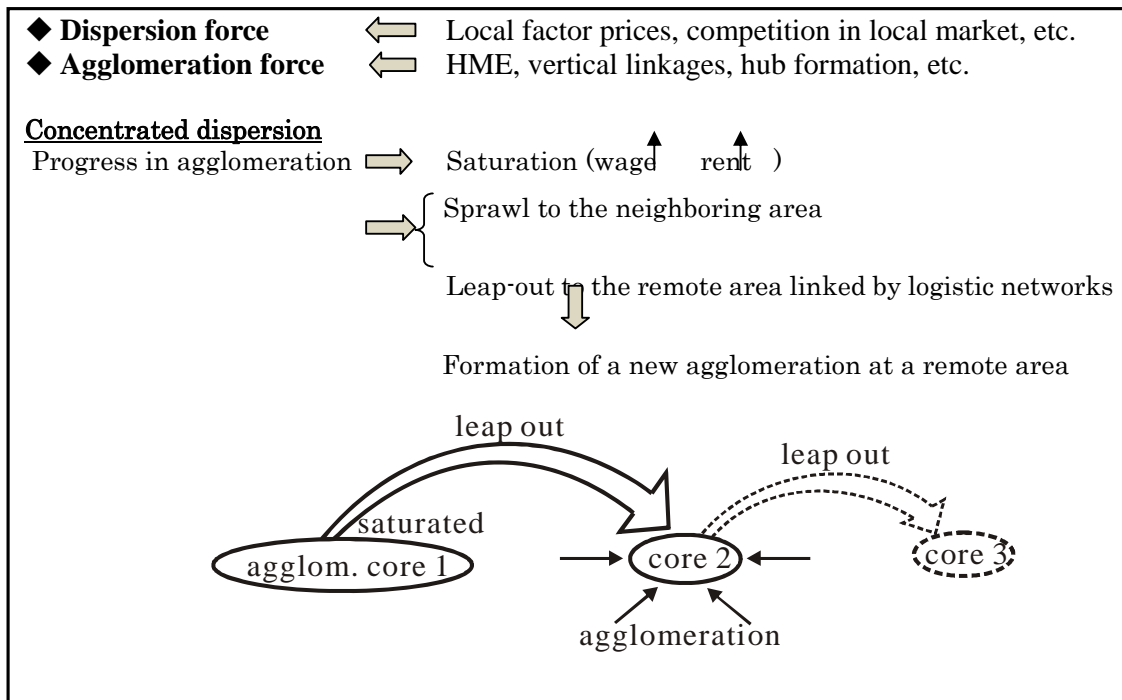

Source: Nishikimi and Kuroiwa (2009).

⁴ World Bank (2009) carries out comprehensive studies of the leaping-out process of industrial agglomeration. Moreover, the leaping-out of plant location may occur within a firm if its production activity is separable into several processes that are suitable for different production sites. Such a firm can gain production efficiency and profitability by relocating the separated processes to suitable production sites and connecting them with an efficient logistic network. This phenomenon is called “fragmentation” (Figure 1) and is widely observed in recent East Asia.

How concentrated dispersion may be lured into a particular country is probably the greatest concern for less developed countries which aim to industrialize their economies by participating in production networks and forming competitive industrial clusters.

6. INDUSTRIAL POLICY REVISITED

A. Attracting production blocks—from where?

Less developed Southeast Asian countries would have an opportunity for industrial development by participating in production networks. However, their engagement in these networks need not start from scratch. They can utilize existing networks based in the neighboring countries. For example, the Lao economy is already involved in the production networks of MNEs based in Thailand, brought about by geographical proximity as well as their cultural and linguistic affinity. Production networks in East Asia are becoming increasingly regionalized, whereas the market for their final products is more globalized, directed mostly to the developed world (Kuroiwa 2009).

As emphasized by Dicken (2007), “simple geographical proximity is, itself, a very powerful stimulus for integrating operations.” Geographical proximity, for example, reduces the time involved in managerial oversight, facilitates rapid resource exchanges, and lowers transportation and coordination costs (McKendrick et al 2000). It is thus important for less developed Southeast Asian countries to fully utilize these advantages.

In recent years, rising labor costs and an appreciation of currencies in neighboring countries, notably China and Thailand, have been pushing up production costs sharply. At the same time, investors would like to reduce their risks by investing in various countries.

B. Attracting production blocks—in which industry?

As shown above, in labor intensive industries of clothing, footwear, sports goods, and toys, many manufacturers have already shifted labor-intensive activities to low-wage countries, including CLMV. However, since these industries have weak agglomeration economies, they are footloose, meaning that they can easily leave the host countries once wages and rents start to rise.

Production blocks in other prospective industries such as electronics and automotive are more stable and give more repercussions on the local economy. However, since these industries exhibit substantial agglomeration economies and require more sophisticated technological capabilities, it is more difficult to attract them. In particular, the automotive industry is a typical IRS industry. Thus, large countries such as Vietnam, which can offer lucrative domestic market, have a strong advantage in attracting the industry, while it is far more difficult for Cambodia and Lao PDR to participate in the network.⁵

On the other hand, as in the case of more developed Southeast Asian countries, the production network in the electronics industry may spread more extensively. Empirical studies, however, show that Cambodia and Lao PDR had yet to be involved in the electronics production network; in a similar vein, Vietnam was not fully involved yet (Kuroiwa 2009). In view of the vast opportunities provided by the electronics industry, participating in such a network seems critical. The governments of those countries, therefore, need to adopt clear and decisive policies to attract as many production blocks as possible and to diversify and upgrade their industrial base.

C. Attracting production blocks—How?

To attract production blocks, the government needs to adopt appropriate policies to reduce additional costs incurred by production fragmentation, namely setup costs, operation costs, and service link or logistics costs (Chapter 5). When the industry has significant agglomeration economies, the attracted production blocks would invite other production blocks via vertical (backward and forward) linkages. Although these industries bring in more benefits, it is more difficult to attract them. Thus, more efforts must be made to improve the business environment in the host country.

⁵ Compared with the automotive industry, the motorcycle industry, for example, requires smaller setup costs, and the economy of scale is less significant. Therefore, the motorcycle industry seems to be more accessible and feasible in small countries. In fact, some motorcycle companies, including major Japanese companies, have already set up assembly plants in Cambodia and Lao PDR. However, such involvement in the network is fragile, given that (1) there is no competitive local parts supplier, and (2) completely built units (CBU) that are produced in the neighboring countries, such as Thailand, may become more competitive if the tariff barriers are removed by AFTA and other regional frameworks. In the end, industrial capability, which is strengthened by industrial clustering, will be critical to remain in the network.

In this context, regional integration must be accelerated to reduce service link costs. For example, AFTA and other regional frameworks are instrumental to remove trade and investment barriers within the region. Development of highway networks—notably the East-West Economic Corridor, the North-South Economic Corridor, and the Southern Economic Corridor—are crucial to reduce transport cost and time in CLMV. Moreover, cross border transport agreements, such as the GMS Cross-Border Transport Agreement (GMS CTBA), are becoming increasingly important to shorten the time for crossing borders.

On the other hand, the establishment of special economic zones (SEZs) is critical to improve the business environment. Since the resources are seriously limited, it is extremely difficult for less developed countries to improve the investment environment all across the country. For example, providing excellent infrastructure services nationwide is too costly and economically unfeasible. Human resources are seriously limited in less developed countries. It is strategically sensible to target specific locations and pour limited resources into the development of the designated areas. In particular, SEZs are quite instrumental to attract foreign direct investment (FDI). This is because (1) SEZs reduce the tax burden of firms owing to the tax holiday, import duty, and other tax exemptions; (2) SEZs provide excellent infrastructure services, including transportation, telecommunications, electricity, gas, and water supply; and (3) SEZs provide one-stop services for company registration, investment licensing, work permits, export and import permits, and so on, which will cut the additional costs incurred by production fragmentation.

Past experiences in East Asia indicate that the establishment of SEZs was effective in attracting the electronics and other machinery industries, which may require more sophisticated business environment than light industries, such as garment. SEZs are being developed in the less developed Southeast Asian countries. For instance, the government of Cambodia has approved 18 SEZs which are strategically located in areas such as Phnom Penh (capital), Sihanoukville (port area), and Bavet (Vietnam–Cambodia border area). In CLMV, these areas: (1) metropolitan area, (2) transport hub, and (3) border area, seem to be promising for attracting FDI. In particular, some specific metropolitan areas and transport hubs may have strong potential in the formation of industrial clusters.

D. Forming competitive clusters

The phase of participating in production networks is followed by a more difficult task of forming competitive clusters. A low labor cost production site can lose the competitiveness of industry if they fail to yield agglomeration economies such as the emergence of specialized personnel, parts suppliers, and technological spillovers. On the other hand, being located in an industrial cluster can enhance productivity, and improve the competitiveness of industry, even if wages are rising.

There are two categories of public policies relevant to cluster development. The first category relates to the overall business environment, such as macroeconomic stability, flexibility of labor markets, provision of general infrastructure, free trade and open investment policies. In addition, building human capital and ensuring good governance (establishing the rule of law, eradicating corruption, and so on) are particularly important to fill the initial gaps between developed and less developed countries. These generic policies are market-friendly and improve the overall business environment in the host countries, so that they can provide the baseline for entry into production networks and subsequent development of industrial agglomerations.

The second category involves measures which promote agglomeration of specialized personnel, suppliers, and information spillover in specific industries so that industrial clusters become more competitive and stable. These policy measures include generous tax incentives and business facilitation for specific industries, building sophisticated physical infrastructures (especially transportation and communication network facilities, industrial parks, and public utilities), providing access to capital, upgrading industry-specific skills and the capacity of local suppliers, and active R & D promotion in specific industries.

However, these policy measures are highly selective in targeting specific industries and demand greater institutional resources. Many developing countries lack strong institutional capabilities and have failed in implementing industry-specific policies. It is therefore more practical for less developed Southeast Asian countries to focus on generic policies. Then, as the industry becomes more mature and upgraded with institutional capability of the state growing sufficient, the measures that promote industrial clustering of specific industries may become more relevant.

Specifically, Lao PDR, Cambodia, and Myanmar need to improve their business environment and attract more production blocks, while industrial cluster development in Vietnam should receive more attention in terms of strengthening the industrial base to increase competitiveness of industry.

CONCLUSION

Since the mid 1980s, CLMV have been undergoing economic transition from central planning to market economies. Moreover, economic reforms in these countries have been accelerated by their accession to the WTO and FTAs. Such economic reforms will increase opportunities to attract production blocks, especially from neighboring East Asian countries.

In Southeast Asia, production networks expanded in the electronics and automotive industries. In particular, the electronics industry diversified procurement of inputs and became a leading force of economic integration. CLMV are already involved in the apparel production network, but it is becoming crucial for them to be engaged in other promising industrial activities. Thus, the governments need to adopt clear and decisive policies to attract as many production blocks as possible and to diversify and upgrade their industrial base.

The two constraints—shrinking policy space and the constraints on state capability—must be considered in exploring the feasible and appropriate industrial policies. Many of those policy measures that focus on participation in production networks and the formation of competitive clusters are market-friendly and seem to conform to the constraint on shrinking policy space. However, the generic policies should be given priority for the less developed Southeast Asian countries, taking into account both their institutional capabilities and stages of economic development. The measures that promote the industrial clustering of specific industries may become more relevant, as the industry becomes more mature and upgraded, and if, at the same time, the institutional capability of the state grows sufficient.

AFTA and other regional frameworks will be instrumental to remove trade and investment barriers. Moreover, infrastructure development such as the East-West,

North-South, and Southern Economic Corridors—in tandem with GMS Cross-Border Transport Agreement—will significantly reduce transport cost and time. The establishment of SEZs seems to be effective in attracting the industries which may require more sophisticated business environment than light industries, such as garment.

REFERENCES

Ando, Mitsuyo (2009). “International Production/Distribution Networks in East Asia”. Unpublished manuscript.

Arndt, Sven W. and Henryk Kierzkowski (2001). “Introduction”. In *Fragmentation: New Production Patterns in the World Economy*, ed. Sven W. Arndt and Henryk Kierzkowski. Oxford: Oxford University Press.

Bora, Bijit, Peter J. Lloyd, and Mari Pangestu (2000). “Industrial Policy and the WTO”. Policy Issues in International Trade and Commodities Studies Series No. 6. Geneva: United Nations Conference on Trade and Development.

Chia Siow Yue (2004). “Integrating East Asia’s Low Income Countries into the Regional and Global Market”. Paper presented at OECD Research Project on The Impact and Coherence of OECD Country Policies on Asian Developing Economies, 10-11 June. Paris.

_____ (2006). “*Integrating the Mekong Region into ASEAN*”. Paper presented at the seminar on Accelerating Development in the Mekong Region: The Role of Economic Integration, 26-27 June. Siem Reap, Cambodia,

Dicken, Peter (2007). *Global Shift: Mapping the Changing Contours of the World Economy (5th Edition)*. London: SAGE Publications.

JETRO. Comparison of Investment Cost, JETRO-FILE. <http://www3.jetro.go.jp/jetro-file/cityselect.do> (accessed on 20 February, 2008).

Jones, Ronald W. and Henryk Kierzkowski (1990). “The Role of Services in Production and International Trade: A Theoretical Framework”. In *The Political Economy of International Trade: Essays in Honor of Robert E. Baldwin*, ed. Ronald W. Jones and Ann Kruger. Oxford: Basil Blackwell.

Kimura, Fukunari (2008). “The Mechanics of Production Networks in Southeast Asia: The Fragmentation Theory Approach”. In *Production Networks and Industrial Clusters: Integrating Economies in Southeast Asia*, ed. Ikuo Kuroiwa and Toh Mun Heng. Singapore: Institute of Southeast Asian Studies.

Kuroiwa, Ikuo (2008). “Cross Border Production Networks in Southeast Asia”. In

Production Networks and Industrial Clusters: Integrating Economies in Southeast Asia, ed. Ikuo Kuroiwa and Toh Mun Heng. Singapore: Institute of Southeast Asian Studies.

_____ (2009) "Production Networks and Industrial Policy in Less Developed Southeast Asia In *Plugging into Production Networks: Industrialization Strategy in Less Developed Southeast Asian Countries*, ed. Ikuo Kuroiwa. Singapore: Institute of Southeast Asian Studies, forthcoming.

Lall, Sanjaya (2003). "Reviving Industrial Strategy: The Role of Government Policy in Building Industrial Competitiveness". *G-24 Discussion Paper 28*, April.

Lall, Sanjaya, Manuel Albaladejo, and Jinkang Zhang (2004). "Mapping fragmentation: electronics and automobiles in Southeast Asia and Latin America". *Oxford Development Studies* Vol. 32, No.3, September: 407-32.

Masuyama, Seiji, Donna Vandenbrink, and Chia Siow Yue (ed.) (1997) *Industrial Policies in East Asia*. Singapore, ISEAS; Tokyo: Nomura Research Institute.

McKendrick, David G., Richard F. Donner, and Stephan Haggard (2000). *From Silicon Valley to Singapore: Location and Competitive Advantage in the Hard Disk Drive Industry*. Stanford: Stanford University Press.

Narjoko Dionisius A. and Puspa Delima Amri (2007). "The Development Gap between the ASEAN Member Countries: The Perspective of Indonesia". *ASEAN Economic Bulletin 24*, No. 1:45-71.

Nishikimi, Koji and Ikuo Kuroiwa (2009). "Analytical Framework for East Asian Economic Integration: Dispersion, Agglomeration and Concentrated Dispersion". Unpublished manuscript.

Ohno, Kenichi (2003). "Vietnam's Industrialization Strategy in the Age of Globalization." <http://www.grips.ac.jp/module/vietnam/main_en.pdf> (accessed on 20 February, 2008).

Pangestu Mari (2002). "Industrial Policy and Developing Countries". In *Development, Trade, and the WTO: A Handbook*, ed. Bernard Hoekman, Aaditya Mattoo, and Philip English. Washington DC: World Bank.

Sturgeon, Timothy and Richard Lester (2004). "The New Global Supply-base: New Challenges for Local Suppliers in East Asia". In *Global Production Networking and Technological Change in East Asia*, ed. Shahid Yusuf, M. Anjum Altaf and Kaoru Nabeshima. Washington DC: World Bank.

Suzuki, Motoyoshi (2009). "Industrialization Strategy of Laos: Agglomeration and Fragmentation". In *Plugging into Production Networks: Industrialization Strategy in Less Developed Southeast Asian Countries*, ed. Ikuo Kuroiwa. Singapore: Institute of Southeast Asian Studies, forthcoming.

World Bank (1997). *World Development Report 1997: The State in a Changing World*. Washington DC: World Bank.

_____ (2009). *World Development Report 2009: Reshaping Economic Geography*. Washington DC: World Bank.

